

# 40 GHz phase shift experiments of WDM-based optically controlled transmitting array antenna

Abhijeet Gupta<sup>1</sup>, Dr. Sudhir Kumar<sup>2</sup>  
<sup>1</sup>Research Scholar, Mewar University, Chittorgarh, India  
<sup>2</sup>ISM, Dhanbad, INDIA

## 1. Introduction

Advanced satellite communications system needs large-scale satellite-borne antenna with a function of beam steering and/or multiple spot beams to cover wide service area with high antenna gain. Although phased array antenna is very useful for the feed for the large reflector to satisfy the requirements above, it generally causes increase in the equipment weight, feed loss, and complexity in beam forming network as increase of the number of the antenna elements and the frequency. Especially for the array antenna in Ka-band or millimeter-wave uses, it is important to reduce the size, weight and insertion loss of the beam forming network. One of promising technologies to overcome these difficulties is application of the optically controlled array antenna for the satellite-borne antenna. In the array antenna, RF signals are optically modulated, transmitted via optical fiber, and phase and amplitude of each RF signal are controlled by using the optical beam forming network. Optically controlled array antennas using optical delay lines with different length [1] and spatial light modulator [2] are proposed and experimentally verified in Japan as research on optically controlled array antenna specialized for Ku- and Ka-band satellite communications use. On the other hand, optical dispersion techniques having true-time delay characteristics suitable for wide/multi-bandwidth operation are also proposed and verified [3], [4], although temperature instability of the delay in the optical fiber is one of the technical issues. In this paper, the WDM-based optically controlled array antenna consists of WDM optical sources and an optical dispersion fiber is fundamentally investigated aiming for future millimetrewave satellite communication use. Since the proposed WDM-based array antenna has true-time delay characteristics suitable for wide/multi-bandwidth operation and uses only the difference in time delay at each wavelength within the same fiber and does not cause microwave phase instability due to temperature, it is suitable to realize complex beam forming using array antenna with wide/multi-bandwidth operation. We have already experimentally verified 20 GHz phase characteristics of WDM-based optically controlled array antenna for both transmitting and receiving antenna [5]. In order to verify phase accuracy of the proposed array antenna at millimeter-wave frequency, 40 GHz phase shift experiments of WDM-based optically controlled array antenna for transmission is reported.

## 2. Principle of operation

Figure 1 shows schematic diagrams of the proposed optically controlled array antenna for both transmission and reception. Thick line shows optical components and thin line shows microwave ones. In the transmitting antenna shown in Figure 1(a), chromatic dispersion of a single mode fiber is used to control microwave phase to be fed to each antenna element for beam steering. First, different-wavelength optical carriers  $\lambda_1 - \lambda_n$  are combined by the optical multiplexer and modulated with microwave signal. The modulated optical carriers are delayed by the effect of chromatic dispersion at each wavelength when it passes the single mode fiber. The delayed optical signals with wavelengths  $\lambda_1 - \lambda_n$  are demultiplexed and detected by the photodiode corresponding to each wavelength. Phase difference in each antenna element is proportional to the delay at each wavelength. In the receiving antenna shown in Figure 1(b), the optical carrier  $\lambda_1 - \lambda_n$  is modulated by the microwave signal received at each antenna element. Modulated optical signals are multiplexed and delayed at each wavelength in the single mode fiber. If the SMF length and optical wavelengths are adjusted to align the phase of each antenna element, all the received microwave signals are added with the same phase by the detection at a photodiode. In both the transmitting and receiving antennas, delay time difference  $\tau_{opt}$  between adjacent Wavelengths can be expressed as

$$\tau_{opt} = DL\Delta\lambda_{opt} \quad (1)$$

Where, D is wavelength dispersion of the SMF, L is the SMF length and  $\Delta\lambda_{opt}$  is wavelength spacing. Microwave phase difference  $\Delta\phi$  between adjacent antenna elements can be expressed as

$$\Delta\phi = 2\pi DL\Delta\lambda_{opt} f_{RF} \quad (2)$$

Where,  $f_{RF}$  is the microwave frequency.

Only the single mode fiber acts as microwave phase shifters in the WDM-based optically controlled array antenna. Optical carrier of a different wavelength is assigned to each antenna element and is able to adjust the microwave phase if the wavelength is variable. Since the number of phase shifters is decreased, reduction of complexity and weight in the beam forming network will be expected. Moreover, since wavelength dispersion characteristics of the SMF is invariant and each wavelength can be adjusted to control the phase of corresponding microwave signal, WDM based phase shifter is expected to be less affected by surrounding environmental condition than the phase shifter using optical delay lines with different length. It is expected to be able to attain very stable microwave phase shifters independent of inaccuracy in the fiber length due to temperature.

### **3. Experiments**

#### **3.1 Experimental setup**

In order to investigate millimetre-wave phase accuracy and stability of the proposed WDM based optically controlled array antenna, phase shift experiments using 4-element array antenna for transmission were carried out at 40 GHz. Experimental setup of WDM-based optically controlled array antenna is shown in Figure 2. Thick line shows optical components and thin line shows microwave ones. Four optical carriers generated from DFB lasers with wavelengths of 1559.79, 1558.98, 1558.17 and 1557.36 nm based on 100 GHz ITU grid are multiplexed and modulated by 40 GHz millimetre-wave signal generated from the network analyzer. Only one single mode fiber was used for optical delay and the fiber was replaced in order to change the phase to steer the beam in the experiments. Finally, delayed optical signals are demultiplexed to each wavelength and detected to 40 GHz signal by each photodiode. 40 GHz phase of each element was relatively measured using the network analyzer by switching the output of each photodiode.

#### **3.2 Experimental results**

Measured 40 GHz phase characteristics of 4-element WDM-based optically controlled array antenna for transmission are shown in Figure 3. The SMF length  $L$  is changed to 50, 100 and 200 m in the figure. 40 GHz phases corresponding to the wavelengths of  $\lambda_2 = 1558.98$ ,  $\lambda_3 = 1558.17$  and  $\lambda_4 = 1557.36$  nm are shown relative to the phase corresponding to  $\lambda_1 = 1559.79$  nm. Since the measured phases agree well with the calculated ones, standard deviation of the obtained phases corresponding to each wavelength and fiber length are shown in Table 1 in order to investigate the phase deviation precisely. Although obtained phase deviation is slightly increased as the fiber length is increased, 40 GHz phase deviation of less than 4 deg. is obtained using the WDM-based optically controlled array antenna. Moreover, in order to clarify the frequency dependence on phase accuracy, modulation frequency was changed to 20, 30 and 40 GHz. Table 2 indicates standard deviation of the obtained phases corresponding to each frequency. The SMF length at each frequency was shortened to be inversely proportional to the frequency. Phase deviation of less than 4 deg. is obtained independent of the measured frequency. 40 GHz radiation pattern of 4- element linear array antenna is also estimated from the measured 40 GHz phase characteristics and compared with calculated pattern based on the wavelength dispersion of the single mode fiber in Figure 4. Microstrip antenna is assumed as an element antenna. Obtained beam scan angle is 2.5, 4.5 and 9.0 deg. with the fiber length of 50, 100 and 200 m, respectively. The patterns estimated from the experimental phase values coincide well with those calculated from the wavelength dispersion of the fiber

### **4. Conclusion**

WDM-based optically controlled array antenna consists of WDM optical sources and an optical dispersion fiber aiming for satellite communication use was experimentally verified. 40 GHz phase accuracy of 4-element WDM-based optically controlled array antenna composed of four DFB lasers and one SMF was measured. The SMF length was changed to 50, 100 and 200 m in order to shift the phase and steer the beam direction. Measured 40 GHz phases are coincided well with calculated values and phase deviation of less than 4 deg. is realized. Also 40 GHz radiation pattern estimated from the measured phases agrees well with the pattern calculated from the optical characteristics. Availability of the WDM-based optically controlled phase shifter to millimeter wave phased array antenna was fundamentally verified.

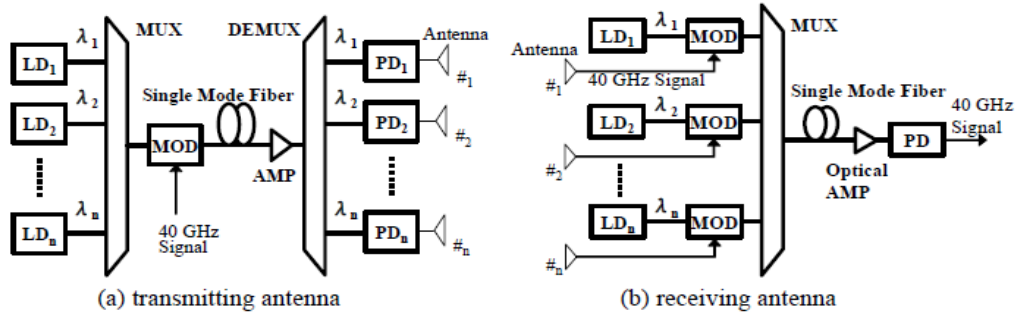

Figure 1: Schematic diagram of WDM-based optically controlled array antenna.

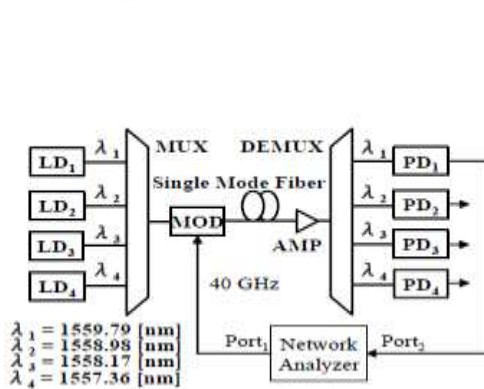

Figure 2: Experimental setup of 4-element optically controlled array antenna.

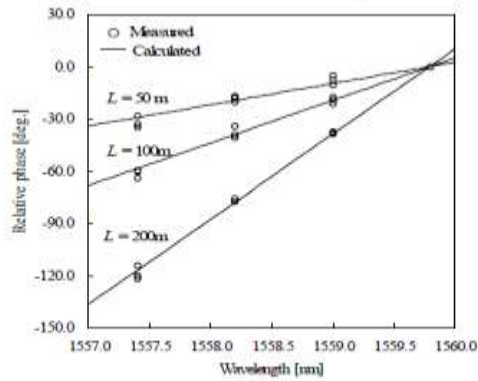

Figure 3: Measured 40 GHz phases at SMF length  $L = 50, 100$  and  $200$  m.

Table 1: Standard deviation of measured 40 GHz phase at each wavelength and SMF length.

	$L = 50$ m	$L = 100$ m	$L = 200$ m
$\lambda_2 = 1558.98$ nm	2.1 deg.	1.5 deg.	0.4 deg.
$\lambda_3 = 1558.17$ nm	1.3 deg.	2.7 deg.	0.7 deg.
$\lambda_4 = 1557.36$ nm	2.7 deg.	1.8 deg.	3.2 deg.

Table 2: Standard deviation of measured 20 - 40 GHz phase at each wavelength and SMF length for comparison.

	20 GHz $L = 400$ m	30 GHz $L = 270$ m	40 GHz $L = 200$ m
$\lambda_2 = 1558.98$ nm	0.9 deg.	0.3 deg.	0.4 deg.
$\lambda_3 = 1558.17$ nm	2.7 deg.	2.5 deg.	0.7 deg.
$\lambda_4 = 1557.36$ nm	3.9 deg.	3.2 deg.	3.2 deg.

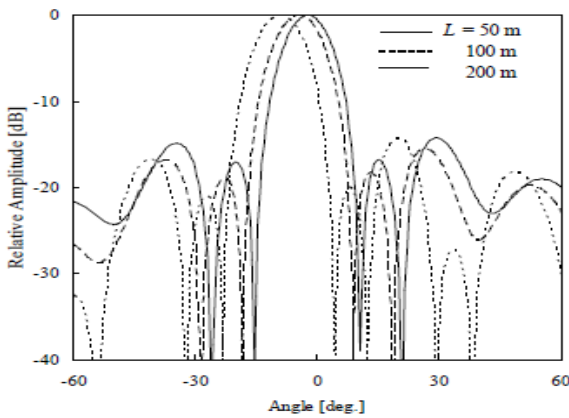

(a) estimated from measured 40 GHz phases

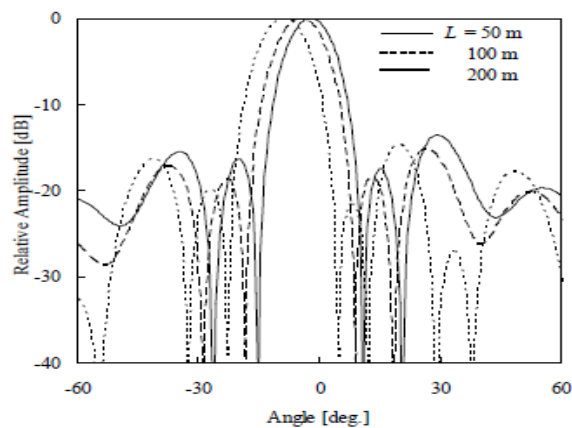

(b) calculated from optical characteristics

Figure 4: 40 GHz radiation pattern of 4-element linear array antenna with fiber lengths  $L = 50, 100$  and  $200$  m.

### References

- [1]. Y. Fujino, M. Sato, M. Tanaka, S. Taira, N. Obara, R. Iwamoto, "Fundamental experiment of optical phased array antenna for satellite communication," IEICE Technical Report, no. SAT2006-5, pp. 24-28, 2012.
- [2]. T. Akiyama, J. Suzuki, T. Ando, T. Nagatsuka, Y. Hirano, "Phase-only spatial light modulator based optically controlled phased array antenna," 2006 IEICE Society Conference, no. C-14-6, p. 254, 2010.
- [3]. D. T. K. Tong, M. C. Wu, "A novel multiwavelength optically controlled phased array antenna with a programmable dispersion matrix," *Photon. Technol. Lett.*, vol. 8, no. 6, pp. 812-814, 2009.
- [4]. B. Vidal, T. Mengual, C. Ibanez-Lopez, J. Marti, I. McKenzie, E. Vez, J. Santamaria, F. Dalmases, L. Jofre, "Simplified WDM optical beamforming network for large antenna arrays," *Photon. Technol. Lett.*, vol. 18, no. 10, pp. 1200-1202, 2006.
- [5]. W. Ohuchi, W. Chujo, Y. Fujino, Y. Koyamada, "Phase control experiments of 20 GHz optically controlled array antenna using wavelength dispersion of an optical fiber," IEICE Technical Report, no. SAT2006-52, pp. 13-18, 2006.

