

IoT Based Solar Traking and Monitoring System with ESP 32

Prof. Aishwarya Sankpal¹, Miss.Ghumare Priyanka², Miss.Bhavle Asha³, Miss.Sakhare Rutuja⁴

^{1,2,3,4} E & TC Dept. GSMCOE, Balewadi, Pune.
Genba Sopanrao Moze College of Engineering, Balewadi, Pune.

ABSTRACT

An IoT-based solar tracking and monitoring system using ESP32, servo motor, LDR sensor, voltage sensor, current sensor, temperature sensor, and Blynk app is proposed. The system tracks the sun's position and adjusts the solar panel, accordingly, maximizing the amount of sunlight that hits the panel and increases the efficiency of the solar system. The system also monitors various parameters of the solar system, such as voltage, current, temperature, and light intensity, and sends this data to the Blynk app for real-time monitoring. The system is implemented using an ESP32 microcontroller, which is a low-cost and powerful microcontroller with built-in Wi-Fi and Bluetooth connectivity. The ESP32 is connected to a servo motor, which is used to rotate the solar panel. The ESP32 is also connected to the LDR sensor, voltage sensor, current sensor, and temperature sensor. The system is implemented using an ESP32 microcontroller, which is a low-cost and powerful microcontroller with built-in Wi-Fi and Bluetooth connectivity. The ESP32 is connected to a servo motor, which is used to rotate the solar panel. The ESP32 is also connected to the LDR sensor, voltage sensor, current sensor, and temperature sensor sun. If the light intensity is below the threshold, the ESP32 will stop rotating on the solar panel. The ESP32 also reads the voltage, current, and temperature sensors and sends this data to the Blynk app. The system works by first reading the light intensity from the LDR sensor. If the light intensity is above a certain threshold, the ESP32 will rotate the solar panel towards the

INTRODUCTION

Solar energy is a renewable and clean source of energy that is becoming increasingly popular. However, solar panels can be expensive to install and maintain. One way to reduce the cost of solar energy is to use a solar panel monitoring and sun tracker system. A solar panel monitoring system allows users to track the performance of their solar panels and identify any problems early on. This can help to extend the lifespan of the solar panels and save money on repairing a sun tracker system, which is a device that moves throughout the day. This can increase the amount of energy generated by the solar panels by up to 25%.

An IoT-based solar tracking and monitoring system using ESP32, servo motor, LDR sensor, voltage sensor, current sensor, temperature sensor, and Blynk app can be used to track the position of the sun and monitor the performance of a solar panel system. The system uses an ESP32 microcontroller to control the servo motor and collect data from the sensors. The data is then sent to the Blynk app, where it can be displayed in real time on a smartphone or tablet.

The system can be used to improve the efficiency of solar panel systems by ensuring that the panels are always facing the sun. It can also be used to detect and diagnose problems with the solar panel system, such as underperforming panels or faulty wiring. Solar energy is a clean and renewable source of energy that is becoming increasingly popular. However, the efficiency of solar panels can be reduced by factors such as shading and dust accumulation. An IoT-based solar tracking and monitoring system can help to improve the efficiency of solar panels by tracking the position of the sun and monitoring the performance of the solar panel system.

The system consists of the following components:

ESP32 microcontroller: The ESP32 is a powerful and versatile microcontroller that is well-suited for IoT applications.

Servo motor: The servo motor is used to track the position of the sun.

LDR sensor: The LDR sensor is used to measure the intensity of light.

Voltage sensor: The voltage sensor is used to measure the voltage output of the solar panel.

Current sensor: The current sensor is used to measure the current output of the solar panel.

Temperature sensor: The temperature sensor is used to measure the temperature of the solar panel.

Blynk app: The Blynk app is used to display the data from the sensors in real time on a smartphone or tablet.

The ESP32 microcontroller controls the servo motor and collects data from the sensors. The data is then sent to the Blynk app. The IoT-based solar tracking and monitoring system has several benefits, including:

Increased efficiency of solar panels: By tracking the position of the sun, the system can ensure that the solar panels are always facing the sun, which maximizes the amount of sunlight that is absorbed.

Reduced maintenance costs: The system can detect and diagnose problems with the solar panel system, such as underperforming panels or faulty wiring. This can help to reduce the cost of maintenance and repairs.

Improved safety: The system can monitor the temperature of the solar panels and generate an alert if the temperature exceeds a safe threshold. This can help to prevent fires and other safety hazards. The system is based on totally online monitoring and manipulate gadgets for Renewable power resources." laptop, Communications, and control era (I4CT), 2014 international conference Atiana

LITERATURE SURVEY

1. Gupta, S. (2020, December 15). IoT Based Solar Panel Power Monitoring using ESP32 and Thing Speak. Circuit Internet of Things (IoT) technologies, along with economies of scale and advances in hardware, software, and network technologies, have accelerated the explosion of connected objects across the Internet. A connected object can be controlled online from an IoT platform and can send, receive, and process various and varied data. In this chapter, we leverage some of the IoT technologies to propose a simple and low-cost IoT solution to monitor and control a smart dual-axis solar tracker system for performance evaluation.
2. Electronics. (n.d.). IoT Based Solar Power Monitoring System with ESP32. How2Electronics. The solution also includes alert notifications to inform a remote user through phone or mail (or both) when a sensor has reached a certain predefined event. The solution is designed based on low-cost and easy-to-use hardware and software and an online open- source IoT platform. The design aspects of the IoT-based solar tracker are extensively described in this chapter. Moreover, a prototype of the IoT-based solar tracker has been manufactured and tested. Test results demonstrate that solar tracker data can be sent easily and properly and can be directly monitored online, as well as the solar tracker, can take commands from the IoT monitoring application.
3. Utilize the Bluetooth interface of Android pills or mobile telephones as a verbal exchange link. And additionally for replacing facts with the assistance of virtual hardware of the electricity Conditioning Unit.
4. Ersan KABALCI: Introduces tracking of a renewable power era machine this is constituted with solar panel arrays. And in which he explained the implementation of the tracking gadget, the tracking device platform is primarily based on modern and voltage measurements of each renewable supply, and the related values are measured with a sensing circuit, and the coded visible interface of monitoring software can manage the saved facts to research the values of each size.

METHODOLOGY

An IoT-based solar tracking and monitoring system consists of a microcontroller, sensors, actuators, and a cloud-based platform. The microcontroller is used to control the actuators and collect data from the sensors. The data is then sent to the cloud-based platform, where it can be stored, analyzed, and visualized. The sensors typically used in IoT-based solar tracking and monitoring systems include:

Methodology for creating an IoT-based solar tracking and monitoring system using ESP32, servo motor, LDR sensor, voltage sensor, current sensor, temperature sensor, and Blynk app.

Hardware:

Sr. No	Component name	Specifications										
1	ESP32	Ultra low power (ULP) co-processor Memory: 520 KiB RAM, 448 KiB ROM Wireless connectivity: Wi-Fi: 802.11 b/g/n. Bluetooth: v4.2 BR/EDR and BLE										
2	LDR sensor	The LDR sensor is used to measure the intensity of light. Light Dependent Resistor or LDR or Photo resistors are electronic components that are often used in electronic circuit designs where it is necessary to detect the presence or the level of light .										
3	Voltage sensor	Voltage sensors are devices that measure the voltage of an electrical circuit. Voltage is the potential difference between two points in an electrical circuit, and it is measured in volts (V).										
4	Current sensors	Current sensors devices that detect and measure the electric current passing through a conductor. They are used in a wide variety of applications, including motor control, power electronics, and battery.										
5	Solar panel	Solar panels are made up of many smaller units called photovoltaic cells. <table border="1" style="width: 100%; border-collapse: collapse;"> <thead> <tr> <th>Feature</th> <th>Residential Panels</th> </tr> </thead> <tbody> <tr> <td># of Solar Cells</td> <td>60</td> </tr> <tr> <td>Average Length (inches)</td> <td>65</td> </tr> <tr> <td>Average Width (inches)</td> <td>39</td> </tr> <tr> <td>Average Depth (inches)</td> <td>1.5 - 2</td> </tr> </tbody> </table>	Feature	Residential Panels	# of Solar Cells	60	Average Length (inches)	65	Average Width (inches)	39	Average Depth (inches)	1.5 - 2
Feature	Residential Panels											
# of Solar Cells	60											
Average Length (inches)	65											
Average Width (inches)	39											
Average Depth (inches)	1.5 - 2											
6	Blynk app	The Blynk app is a mobile app for controlling and monitoring IoT devices. It works by connecting to a cloud server, which in turn communicates with your devices. Provides a drained-drop interface for creating dashboards, which you can use to visualize data from your devices and send commands to them.										
7	Servo motor	A servo motor is a type of electric motor that can be controlled to rotate to a specific position. Servo motors are used in a wide variety of applications, including robotics, automation, and radio-controlled models. Servo motors work by using a closed-loop control system.										

Block Diagram

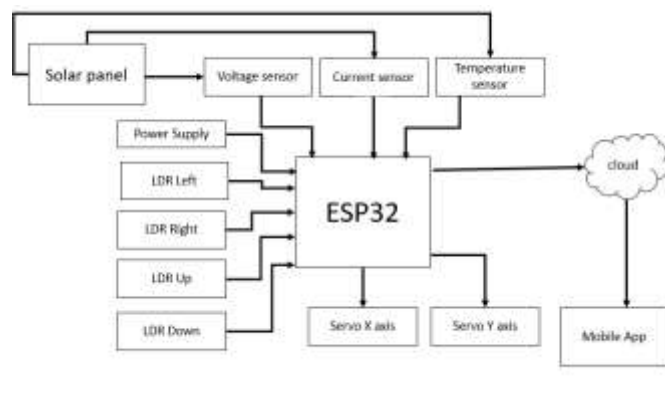

Working of block diagram

Working:

The solar panel will generate electricity and the current sensor and voltage sensor will measure the current and voltage output of the solar panel. The LDR sensor will detect the position of the sun. The temperature sensor will measure the temperature of the solar panel. The ESP32 will collect all this data and send it to the Blynk app. You can then use the Blynk app to monitor the performance of your solar panel and control the servo motor to track the sun.

Here is a more detailed explanation of how each component works:

The solar panel converts sunlight into electricity. The current sensor measures the amount of current flowing through a circuit. The voltage sensor measures the voltage drop across a circuit. The LDR sensor (light-dependent resistor) is a sensor that changes its resistance based on the amount of light it receives. The temperature sensor measures the temperature of its environment. The ESP32 is a microcontroller that can be used to collect data from sensors, control devices, and communicate over the internet. The Blynk app is a mobile app that allows you to create dashboards to monitor and control devices connected to the internet.

Once you have connected all of the components and uploaded the Blynk app, you can start monitoring your solar panel and controlling the servo motor to track the sun. To monitor your solar panel:

1. Open the Blynk app.
2. Tap on the dashboard that you created.
3. You will see the current voltage, current, power output, and temperature of your solar panel.
4. To control the servo motor:
5. Tap on the servo motor widget.
6. Drag the slider to the desired angle.
7. The servo motor will move to the desired angle.

The steps involved in assembling all the devices and implementing the project:

Steps involved in assembling a solar panel monitoring and sun tracker using ESP32, servo motor, solar panel, current sensor, voltage sensor, LDR sensor, temperature sensor, and Blynk app:

1. Connect the solar panel to the ESP32. Use a voltage regulator to reduce the voltage from the solar panel to a safe level for the ESP32 (3.3V).
2. Connect the current sensor to the ESP32. This will allow you to measure the current output of the solar panel.
3. Connect the voltage sensor to the ESP32. This will allow you to measure the voltage output of the solar panel.
4. Connect the LDR sensor to the ESP32. This will allow you to detect the position of the sun.
5. Connect the temperature sensor to the ESP32. This will allow you to measure the temperature of the solar panel.
6. Connect the servo motor to the ESP32. This will allow you to control the movement of the solar panel.
7. Connect the ESP32 to the Blynk app. This will allow you to monitor the data from the solar panel and control the servo motor remotely.

8. Use a breadboard and jumper wires to prototype the circuit before soldering it together.
9. Make sure to use a voltage regulator to protect the ESP32 from the high voltage from the solar panel.
10. Use a current sensor that can handle the maximum current output of the solar panel.
11. Use a servo motor that is powerful enough to move the solar panel.
12. Use a temperature sensor that can withstand the high temperatures of the solar panel.
13. Make sure to mount the solar panel in a location where it will receive direct sunlight throughout the day.
14. Mount the LDR sensor so that it has a clear view of the sun.
15. Mount the servo motor so that it can move the solar panel to the desired position.
16. Use a sturdy enclosure to protect the circuit from the elements.

SOFTWARE COMPONENT

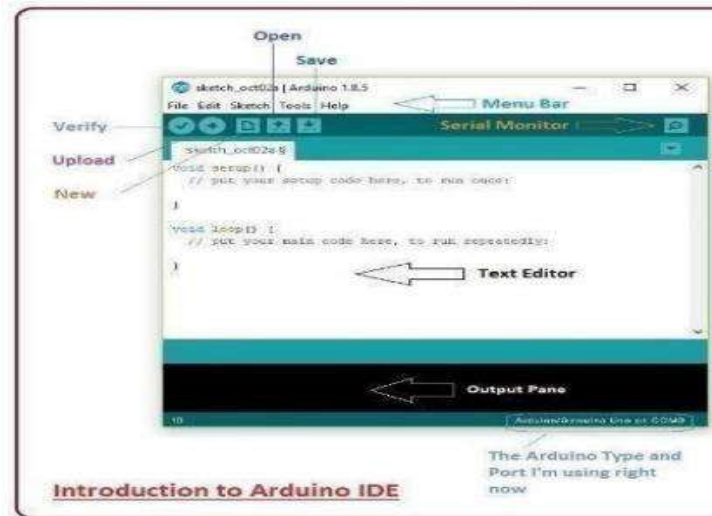

RESULT



CONCLUSIONS

An IoT-based solar tracking and monitoring system using ESP32, servo motor, LDR sensor, voltage sensor, current sensor, temperature sensor, and Blynk app is a cost-effective and efficient way to improve the efficiency, performance, reliability, and safety of solar systems. It is also a valuable tool for data-driven decision-making and remote monitoring.

By tracking the sun's position and monitoring various parameters of the solar system, the system can help to: Increase energy production Improve system performance. Reduce maintenance cost Enhance safety.
The system is easy to implement and can be used in a variety of applications. It can also be integrated with other IoT devices to further enhance its functionality.

Overall, an IoT-based solar tracking and monitoring system is a valuable tool for anyone who wants to improve the performance and reliability of their solar system.

FUTURE SCOPE

The future scope of IoT-based solar tracking and monitoring systems is very promising. As the cost of IoT components continues to decrease and the technology becomes more sophisticated, we can expect to see these systems become more widely used in a variety of applications.

Some of the areas where IoT-based solar tracking and monitoring systems are likely to have a significant impact in the future include:

Smart cities: IoT-based solar tracking and monitoring systems can be used to create smart cities that are more energy-efficient and sustainable. For example, these systems can be used to control the operation of solar-powered streetlights and other public infrastructure.

Commercial solar power plants: IoT-based solar tracking and monitoring systems can be used to improve the efficiency and performance of commercial solar power plants. For example, these systems can be used to identify and address potential problems with the solar panels or other components of the system.

Residential solar power systems: IoT-based solar tracking and monitoring systems can be used to make residential solar power systems more affordable and accessible.

For example, these systems can be used to reduce the need for expensive maintenance and repairs.

In addition to these specific applications, IoT-based solar tracking and monitoring systems are also likely to play a role in the development of new and innovative ways to use solar energy. For example, these systems could be used to develop new solar-powered products and services, such as solar-powered electric vehicles and solar-powered charging stations. Overall, the future scope of IoT-based solar tracking and monitoring systems is very promising. These systems have the potential to revolutionize the way we generate and use solar energy.

Here are some specific ideas for future research and development around IoT-based solar tracking and monitoring systems:
Developing new and more efficient solar tracking algorithms
Developing new and more affordable IoT components for solar tracking and monitoring systems

Integrating IoT-based solar tracking and monitoring systems

REFERENCES

- [1]. Gupta, S. (2020, December 15). IoT Based Solar Panel Power Monitoring using ESP32 and ThingSpeak. Circuit Digest. <https://circuitdigest.com/microcontroller-projects/iot-solar-panel-power-monitoring-system-using-esp32-and-thingspeak>
- [2]. Electronics. (n.d.). IoT Based Solar Power Monitoring System with ESP32. How2Electronics. <https://how2electronics.com/iot-based-solar-power-monitoring-system-with-esp32/> International Telecommunications Union (2012) Overview of the internet of things
- [3]. Kang B, Kim D, Choo H (2017) Internet of everything: a large-scale autonomic iot gateway. IEEE Trans Multi Scale Comput Syst 3 (3):206–214 3. Ahmed MA, Eltamaly AM, Alotaibi MA, Alolah AI, Kim YC (2020) Wireless network architecture for cyber physical wind energy system.
- [4]. IEEE Access 8:40180–40197 4. Business Insider Intelligence (2020) The internet of things report
- [5]. Haghgi M, Thurow K, Stoll R (2017) Wearable devices in medical internet of things: Scientific research and commercially available devices. Healthc Inform Res 23(1):4– 6. Jia M, Komeily A, Wang Y, Srinivasan RS (2019) Adopting internet of things for the development of smart buildings: a review of enabling technologies and applications. Autom Constr