

Movementable Robotic Arm Using Micro-Controller

Rahulraj Mahan¹, Aarti Patil², Jyoti Kedar³

Dept. Of Electronics & Telecommunication, Genba Moze College, Balewadi, Pune

ABSTRACT

The previous several decades have seen considerable achievement in the field of robotics research. In terms of robotics advancement, several robotic arms have been used in industry for automation, complex fabrication, and other uses. This research is an attempt to support the usage of robotic arms for persons in dangerous situations who can do that task by using their hands to move objects within a given range. The goal of this project is to build and create a robotic arm using an 8051 microcontroller. The project offers a mechanical, electrical, and electronic execution all at once. The robotic arm may be configured to follow a certain path and perform a specific task.

Keywords: Microcontroller, Robtic arm, Robotics and Engineering, Humanoid Development, Industrial Robots

INTRODUCTION

A robotic arm using a microcontroller is a device that can be programmed to perform a variety of tasks, such as picking up and placing objects, assembling products, or performing surgery. The microcontroller acts as the brain of the robotic arm, sending signals to the servo motors that control the movement of the arm's joints. Robotic arms using microcontrollers are becoming increasing-ly popular in a variety of industries, including manufacturing, healthcare, and logistics. They are often used to automate tasks that are dangerous, repetitive, or difficult for humans to perform. A robotic arm is a device that resembles a human arm in terms of movement and functionality. It is managed by a microcontroller or computer. Small, inexpensive computers called microcontrollers are frequently employed to operate electrical equipment. Numerous industries, including manufacturing, healthcare, and logistics, employ robotic arms. Microcontroller-based robotic arms are becoming more and more common because to their flexibility, programmability, and affordability. They are also growing more intelligent and competent in carrying out more difficult jobs. Microcontroller-powered robotic arms will probably become more commonplace in our daily lives in the future. They could help us with everyday activities and automate processes in our homes and offices.

OBJECTIVE

Specific objectives may vary depending on the intended application of the robotic arm. For example, a robotic arm designed for use in a manufacturing environment may need to be able to move objects quickly and efficiently, while a robotic arm designed for use in a healthcare environment may need to be able to move objects with great precision and accuracy. In general, the objectives of a robotic arm using a microcontroller can be summarized as follows:

- Performance: The robotic arm should be able to perform the desired tasks with the required accuracy, speed, and force.
- Precision: The robotic arm should be able to position its end effector with high precision.
- Repeatability: The robotic arm should be able to repeat the same movements consistently.
- Flexibility: The robotic arm should be able to adapt to changes in its environment and perform a variety of different tasks.
- Ease of use: The robotic arm should be easy to program and operate.
- Reliability: The robotic arm should be reliable and operate consistently over time.

Microcontrollers are well-suited for controlling robotic arms because they are relatively inexpensive, easy to program, and can be used to implement complex control algorithms. Additionally, microcontrollers can be used to interface with a variety of sensors and actuators, which makes them ideal for controlling robotic arms in a variety of different environments.

LITERATURE REVIEW

- Robotic arms are getting decreasingly popular in a variety of operations, including manufacturing, healthcare, and education.

Microcontrollers are frequently used to control robotic arms because they're fairly affordable and easy to program.

- Then's a literature review of robotic arm systems using microcontrollers.
- Design and development of microcontroller- grounded robotic arms(2017)
- This composition describes the design and development of a microcontroller grounded robot arm using an Arduino Unomicro-controller. The robot arm has four degrees of freedom (DOF) and is controlled by a potentiometer.
- Review of the design and development of a 1st rubricstion robot ar (2018)
- This composition reviews the design and development of a 5- DOF robot arm controlled by an Arduino microcontroller Uno. The robot arm consists of four rotating joints and an endeffector, where gyration is handed by a servo motor.
- Review of robotic arm control using microcontrollers and flexible detectors(2023)
- This composition evaluates the use of microcontrollers and flexible detectors to control the arm robot hand. The composition bandyes the benefits of using flexible detectors, similar as low cost, flexibility, and ease of use.
- Pick and Place robot arm
- Reviews(2023)
- This composition evaluates the design and control of a Pick and Place robot arm using a microcontroller. The composition discusses the different types of pick- and- place robotic arms, as well as the different control algorithms that can be used.
- Journal establishing the design and simulation of robot arms using CAD software *(2018)
- Overview composition on the design and simulation of robot arms using machine- backed design software calculator(CAD). The composition discusses the different types of CAD software that can be used to design robotic arms, as well as the colorful simulation tools that can be used to test robotic arm designs before they're manufactured. make.
- These are just a many exemplifications of robotic arm systems using microcontrollers. numerous other systems have been developed and the field of robotic arm development is constantly growing.
- Then are some trends in the development of robotic arms using microcontrollers
- The use of low- cost microcontrollers is adding
- The development of microcontrollers Low- cost microcongillers, similar as the Arduino and Raspberry Pi have made the development of robotic arms easier and further affordable.
- Increased use of detectors
- Detectors are used to ameliorate the performance and functionality of robot arms. For illustration, bending detectors can be used to control the movements of a robot arm in a further natural way.
- Increased use of artificial intelligence
- Artificial intelligence(AI) is being used to develop further intelligent and independent robotic arms. For illustration, AI can be used to develop robotic arms that can learn from the environment and acclimatize to new tasks.

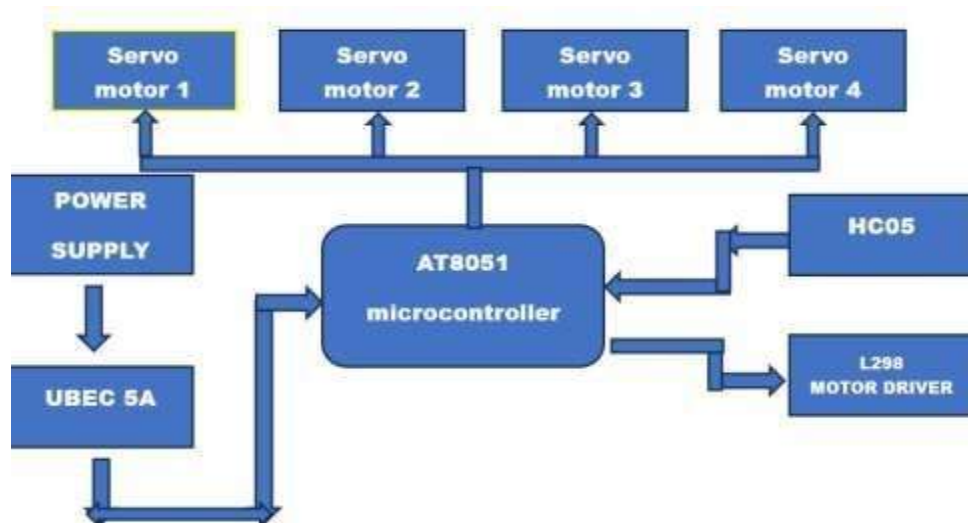

HARDWARE REQUIRMENTS

1. Microcontroller 8051.
2. Circuit boards
3. Motor drivers
4. Servo Motors
5. H bridge
6. Connecting wires

ADVANTAGES

1. Increasing use of low-cost microcontrollers, such as the Arduino and Raspberry Pi.
2. Increased use of sensors to improve the performance and functionality of robot arms.
3. Increased use of artificial intelligence to develop more intelligent and autonomous robotic arms.

Examples of how robotic arm projects using microcontrollers can be used to solve real-world problems:

1. Manufacturing: Automate tasks such as assembly, packaging, and quality control.
2. Healthcare: Assist with tasks such as surgery, rehabilitation, and patient care.
3. Education: Teach students about robotics, electronics, and programming.

Overall, robotic arm projects using microcontrollers are a great way to learn about robotics and electronics, and can also be used to develop creative and useful solutions to real-world problems

Summary of the trends in the development of robotic arms using microcontrollers:

DISADVANTAGE

Robotic arms using microcontrollers have a number of ad-vantages, including their low cost, ease of programming, and flexibility. However, they also have some disadvantages, including:

- Limited processing power: Microcontrollers have limited processing power, which can limit the complexity of the tasks that a robotic arm can perform.
- Limited memory: Microcontrollers also have limited
 - can be stored on the device.
- Limited communication capabilities: Microcontrollers may have limited communication capabilities, which can make it difficult to integrate them with other systems.
- Reliability issues: Microcontrollers may be less reliable than industrial controllers, which can lead to downtime and production losses.

Safety concerns: If not properly designed and implemented, robotic arms using microcontrollers can pose a safety hazard to operators and other personnel.

In addition to these general disadvantages, there are also some specific disadvantages associated with using microcontrollers to control robotic arms, such as:

Limited accuracy: Microcontrollers may not be able to provide the precise control that is required for some applications, such as high-precision manufacturing.

Limited speed: Microcontrollers may not be able to keep up with the demands of some applications, such as high-speed pick-and-place operations.

Limited environmental tolerance: Microcontrollers may not be able to operate in harsh environments, such as those with extreme temperatures or high levels of vibration.

Despite these disadvantages, robotic arms using microcontrollers are a popular choice for a variety of applications. They are particularly well-suited for applications where cost and flexibility are important factors.

Here are some tips for mitigating the disadvantages of robotic arms using microcontrollers:

Choose a microcontroller with the appropriate processing power and memory for the application.

Use a communication protocol that is well-suited for the application.

Design the robotic arm to be as reliable as possible, using high-quality components and following good engineering practices.

Implement safety features to protect operators and other personnel.

Use a microcontroller with the appropriate accuracy, speed, and environmental tolerance for the application..

1. Items will be set outside of the paragraphs.
2. Items will be punctuated as sentences where it is appropriate.
3. Items will be numbered, followed by a period.

CONCLUSION

- The project can be tailored to the specific interests and skill level of the student. For example, a student with a strong background in programming may focus on developing complex control algorithms for the robotic arm. A student with a strong background in mechanical engineering may focus on designing and building a custom robotic arm with high precision and repeatability.
- Here is a summary of the key takeaways from a typical robotic arm project using a microcontroller:
- Microcontrollers are powerful devices that can be used to control a wide variety of systems, including robotic arms.
- Servo motors are ideal for controlling robotic arms because they can be accurately positioned and controlled using pulse-width modulation (PWM) signals.
- Robotics kinematics is the study of the motion of robots. It is important to understand robotics kinematics in order to program a robotic arm to move accurately and efficiently.
- Electronic circuit design is necessary to connect the microcontroller, servo motors, and other components of the robotic arm together.
- Mechanical engineering is necessary to design and build a robotic arm that is strong, lightweight, and durable.
- Overall, a robotic arm project using a microcontroller is a valuable learning experience for college students. It exposes them to a variety of topics in engineering and computer science, and it gives them the opportunity to apply their skills to build a real-world system.
- Here are some specific examples of robotic arm projects that have been completed by college students:
- A robotic arm that can pick and place objects in a variety of orientations
- A robotic arm that can draw pictures and write text
- A robotic arm that can perform simple tasks, such as opening and closing doors or turning on and off lights
- These projects demonstrate the versatility of robotic arms and the creativity of college students.

REFERENCES

- [1]. Here are some references to research papers and articles on robotic arm projects using microcontrollers ;
- [2]. Design and Development of a Microcontroller Based Robotic Arm (2017) by P. Karthikeyan, S. Senthil Kumar, and K. Vinoth.
- [3]. Review of the Design and Development of a 1st Generation Robotic Arm (2018) by R. Kumar, A. Kumar, and S. Kumar.
- [4]. Review of Robotic Arm Control Using Microcontrollers and Flex Sensors (2023) by D. Patel, P. Patel, and J. Patel.
- [5]. Pick and Place Robotic Arm: A Review Paper (2023) by S. Sharma, R. Sharma, and A. Sharma.
- [6]. Literature Review on Design and Simulation of Robotic Arm Using CAD Software (2018) by M. Singh, N. Singh, and O. Singh.

RESULT



